

# A+R

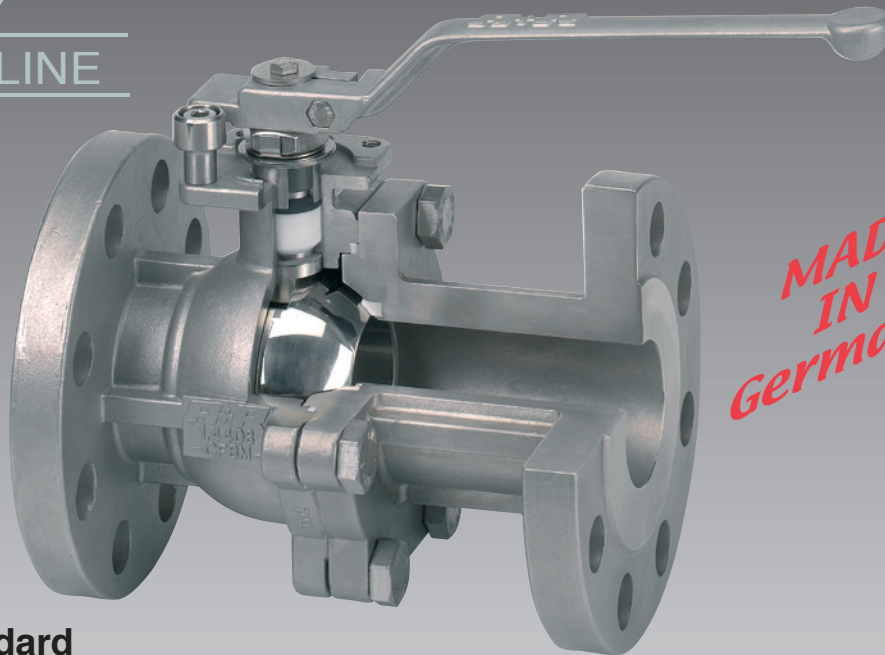

QUALITY  
LINE



**MADE  
IN  
Germany**

**Class ANSI  
300 Lbs  
PTFE - Standard**

## Flansch-Kugelhähne Typ KHL 510

DN 15, 1/2" bis DN 150, 6", ASME B 16.5 - 16.10

<b>Werkstoffe:</b>	<b>-ETE-</b>	<b>-STE-</b>
Gehäuse	1.4408 (CF8M)	1.0619 (WCB)
Dichtungen	PTFE	PTFE
Kugel	1.4408 (CF8M)	1.4308 (CF8)

DIN EN ISO 9001:2000 - TÜV CERT -  
DGRL 97/23/EG  
Herstellung gem. AD-2000  
TA-Luft 2002  
Fire-Safe BS 6755, part 2



**Einsatzbereiche:**  
Neutrale Gase und Flüssigkeiten,  
Mineralölprodukte, Laugen,  
Korrosive Flüssigkeiten und Gase.

**Temperatur:** -50 °C bis +230 °C  
-58 °F bis +446 °F.

## flanged-ball valves type KHL 510

DN 15, 1/2" up to DN 150, 6", ASME B 16.5 - 16.10

<b>materials:</b>	<b>-ETE-</b>	<b>-STE-</b>
body	1.4408 (CF8M)	1.0619 (WCB)
seats	PTFE	PTFE
ball	1.4408 (CF8M)	1.4308 (CF8)

DIN EN ISO 9001:2000 - TÜV CERT -  
PED 97/23/EC  
manufacturing acc. to AD-2000  
TA-Luft 2002  
Fire-Safe BS 6755, part 2



**Application:**  
Water, oil, gas, acid, solution, solvent.

**Temperature:** -50 °C to +230 °C  
-58 °F to +446 °F.

# A+R

# KUGELHÄHNE BALL VALVES

# Flansch-Kugelhähne Typ KHL 510 / flanged-ball valves type KHL 510

ANSI 300 Lbs, PTFE - Standard  
 DGRL 97/23/EG / PED 97/23/EC  
 TA-Luft 2002  
 Fire-Safe BS 6755, part 2; 1987

Ansicht von oben  
 view from top  
 Antriebsaufbau  
 nach DIN ISO 5211  
 actuator attachment  
 acc. to DIN ISO 5211

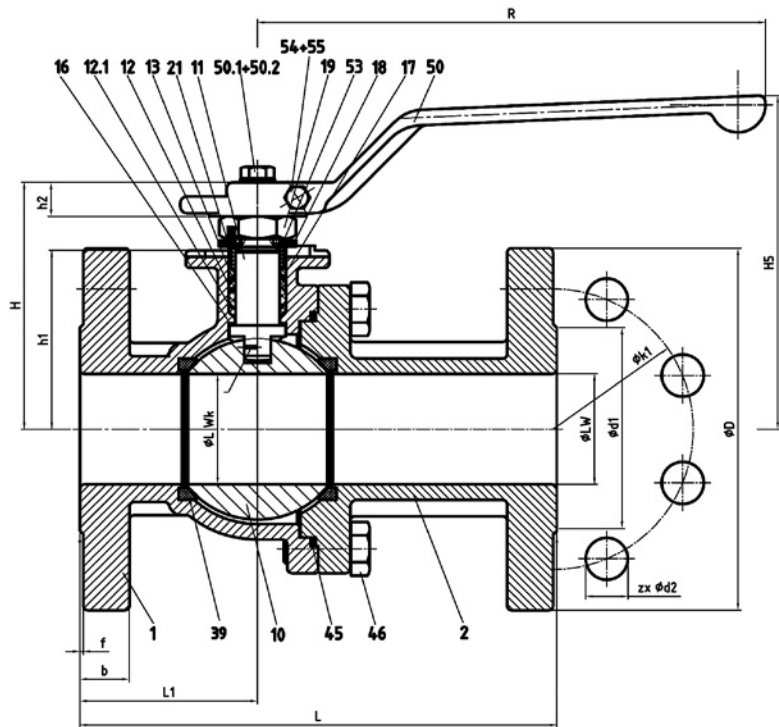
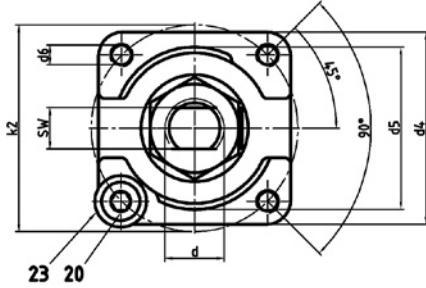

DN	LW	LWk	L	L1	H	H5	h1	h2	d	d1	d2	d4	d5	d6	SW	k1	k2	R	D	b	f	z	Gew. Kg	ISO 5211
½" mm in.	16 0,63	16 0,63	139,7 5,50	48 1,89	75 2,95	121 4,76	55 2,17	9,30 0,37	M16	35,1 1,38	15,7 0,62	45 1,77	35 1,38	M6	12,4 0,49	66,6 2,62	50 1,97	155 6,10	95,3 3,75	14,2 0,56	1,53 0,06	4	2,9	F 05
1" mm in.	25 0,98	25 0,98	165,1 6,50	63 2,48	75 2,95	121 4,76	55 2,17	9,30 0,37	M16	50,1 2,00	19,1 0,75	45 1,77	35 1,38	M6	12,4 0,49	88,9 3,50	50 1,97	155 6,10	123,9 4,88	17,5 0,69	1,53 0,06	4	4,3	F 05
1½" mm in.	38,1 1,5	40 1,58	190,5 7,50	67,5 2,66	101 3,98	144 5,67	73 2,87	13,0 0,50	M20	73,2 2,88	22,4 0,88	65 2,56	55 2,17	M8	14,0 0,55	114,3 4,50	70 2,76	230 9,10	155,5 6,12	20,6 0,81	1,53 0,06	4	9,1	F 07
2" mm in.	50 1,97	50 1,97	215,9 8,50	80,5 3,17	109,5 4,31	153 6,02	81 3,19	13,0 0,50	M20	91,95 3,62	19,1 0,75	65 2,56	55 2,17	M8	14,0 0,55	127 5,00	70 2,76	230 9,10	165,1 6,50	22,4 0,88	1,53 0,06	8	12,0	F 07
3" mm in.	76,1 3	80 3,15	282,5 11,12	92,5 3,64	148 5,83	185 7,28	115 4,53	18,3 0,72	M24	127 5,00	22,4 0,88	95 3,74	70 2,76	M10	19,3 0,76	168,2 6,62	102 4,01	300 11,8	209,6 8,25	28,5 1,12	1,53 0,06	8	27,1	F 10
4" mm in.	100 3,94	100 3,94	304,8 12,0	102,5 4,04	165 6,50	202 7,95	132 5,20	18,3 0,72	M24	157,2 6,19	22,4 0,88	95 3,74	70 2,76	M10	19,3 0,76	200,2 7,88	102 4,01	300 11,8	254 10,0	31,8 1,25	1,53 0,06	8	41,2	F 10
6" mm in.	150 5,91	150 5,91	403,9 15,9	185 7,28	242,5 9,53	252 9,92	184 7,24	34 1,34	M44x1,5	215,5 8,50	22,4 0,88	150 5,91	85 3,35	M12	32 1,26	269,8 10,62	125 4,92	800 31,5	317,5 12,5	36,6 1,44	1,53 0,06	12	110,0	F 12

Pos. item	Benennung	denomination	Werkstoff material	Werkstoff material
55	Mutter	nut	KHL 510-A30-ETE A2-70	KHL 510-A30-STE A2-70
54	Schraube	screw	A2-70	A2-70
53	Sicherungsblech	lock washer	1.4301	1.4301
50.2	Schraube	screw	A2-70	A2-70
50.1	K-Scheibe	washer	A2	A2
50	Handhebel	handle	1.4027	1.4027
46	Schraube	screw	A2-70	A2-70
45	Gehäusedichtung	gasket	PTFE	PTFE
39	Kugeldichtring	seat	PTFE+25%Gl.*	PTFE+25%Gl.*
23	Anschlaghülse	sleeve	1.4305	1.4305
21	Gleitbuchse	slide-bushing	PTFE+50%VA	PTFE+50%VA
20	Schraube	screw	A2-70	A2-70
19	Mutter	nut	A2-70	A2-70
18	Tellerfeder	cup spring	1.4310 / 1.4568	1.4310 / 1.4568
17	Druckring	gland	1.4305	1.4305
16	Gleitring	thrust ring	PTFE+50%VA	PTFE+50%VA
13	Anti-Statik Ring	anti-static ring	PTFE+Carbon	PTFE+Carbon
12.1	Dichtring	stem seal	PTFE	PTFE
12	Dichtring	stem seal	PTFE	PTFE
11	Schaltwelle	stem	1.4401	1.4401
10	Kugel	ball	1.4408 / CF8M	1.4308 / CF8
2	Gehäuse 2	body 2	1.4408 / CF8M	1.0619 / WCB
1	Gehäuse 1	body 1	1.4408 / CF8M	1.0619 / WCB
Pos. item	Benennung	denomination	Werkstoff material	Werkstoff material

\* Standard, optional PTFE pure, PTFE + 50% VA (St.St.), PTFE + 33% Kohle (carbon)

**A+R** - Armaturen® GmbH

D-32107 Bad Salzflufen / Germany  
 Altenhagener Straße 4a • Telefon +49(0)5208-9102-0  
 • Telefax +49(0)5208-9102-90

**A+R** im Internet:

www.ar-armaturen.com  
 e-mail: postoffice@ar-armaturen.com

© A+R Rev. 01 / 11.05. de-en techn. Änderungen vorbehalten / techn. changes reserved